

Description and Application

These thermostats are designed for proportional control of pneumatic valve and damper actuators in HVAC systems. They utilize a highly sensitive bimetal element with feedback and a pilot bleed relay for accuracy and stability.

Models are available with direct or reverse proportional action. The thermostat's throttling range is factory-set and is field adjustable. Setpoints are adjusted using sliders which can be locked or limited using setpoint stops (HFO-0027).

The thermostats require a scale plate assembly and cover. These items may be ordered separately or in a value package (CTC-162X-103) that includes the most commonly ordered accessories (see the Models and Accessories sections).

Specifications

Setpoint Range	55 to 85° F (13 to 29° C), adjustable via slider (adjuster may be concealed and locked or limited)
Throttling Range	3 to 12° F (1.7 to 6.7° C) factory set @ 3° F, field adjustable up to 12° F
Calibration	9 psi (62 kPa) branch pressure
Air	
Supply Pressure	20 psi (138 kPa), 30 psi (207 kPa) maximum
Output Capacity	200 scim (55 mL/s)
Consumption	20 scim (5.5 mL/s)
Material	Black flame-retardant plastic
Weight	3 oz. (85 grams)
Temperature Limits	
Operating	40° to 120° F (4° to 49° C)
Shipping	-40° to 140° F (-40° to 60° C)

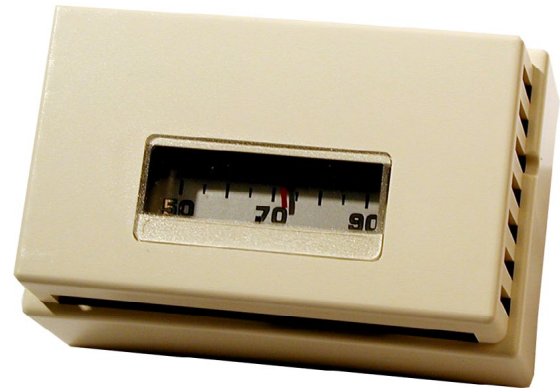

(Shown with Horizontal Scale Plate and Light Almond Cover Installed)

Features

- ◆ Sensitive bimetal element and pilot relay provide consistent, accurate feedback
- ◆ Direct or reverse acting (see the Models section), proportional control of valve or damper actuators
- ◆ Field-adjustable throttling range

Models

CTC-1621	Direct acting
CTC-1621-103	Direct acting, value package*
CTC-1622	Reverse acting
CTC-1622-103	Reverse acting, value package*

*Thermostat value packages contain the necessary components to allow replacement of most Barber-Colman, Johnson Controls, L&G-P, or Robertshaw/Invensys thermostats. They also offer easy ordering of just one part number to furnish all necessary components and mounting hardware for vertically (only) mounted thermostats. In addition to a CTC-1621 or CTC-1622 base, the packages contain these accessories:

HPO-0048-10	°F vertical scale plate
HPO-1511	Light almond, full window, ABS thermostat cover
HMO-5030	Light almond backplate kit with decorative matching plate
HPO-1320	Label strip
HFO-0027	Setpoint stops strip

Accessories

Backplate kit (allows thermostat to be mounted to 2x4 handy box, includes 2 #6-32 screws and decorative matching 2.75 x 4.5" plate):

HMO-5024	Light almond w/ aluminum trim
HMO-5026	White w/ aluminum trim
HMO-5030	Light almond
HMO-5031	White

Thermostat scale plates (includes 2 each HPO-0046 scale plate pins):

HPO-0047-10	° F, horizontal
HPO-0048-10	° F, vertical
HPO-0049-11	° C, horizontal
HPO-0050-11	° C, vertical

Thermostat covers, blank:

HPO-1501	Light almond ABS plastic
HPO-1502	White ABS plastic
HPO-1503	Brushed aluminum

Thermostat covers, full window:

HPO-1511	Light almond ABS plastic
HPO-1512	White ABS plastic
HPO-1513	Brushed aluminum
HPO-1514	White metal
HPO-1516	Light almond metal

Miscellaneous accessories:

HFO-0027	Setpoint stop strip, 4 "stops" per strip
HFO-0028	Tubing kit, 3/32" ID
HMO-5023	Mounting strap for mounting on hollow walls, includes 2 #6-32 x 2" screws and "template" printed on envelope
HPO-0044	Replacement thermostat cover screws
HPO-0046	Replacement scale plate pins
HPO-0051	Replacement cover window for thermostat (1 furnished with each cover)
HPO-1320	Replacement label strip (1 furnished with each cover), 3 labels per strip (for day/night, summer/winter or heating/cooling indication)

Dimensions and Details

All dimension are in inches (mm)

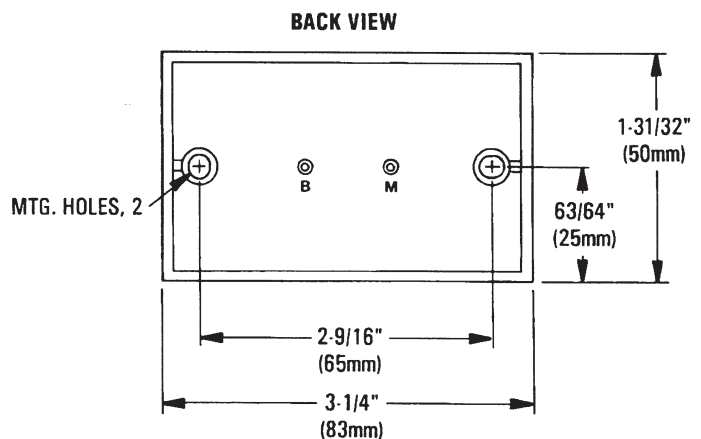
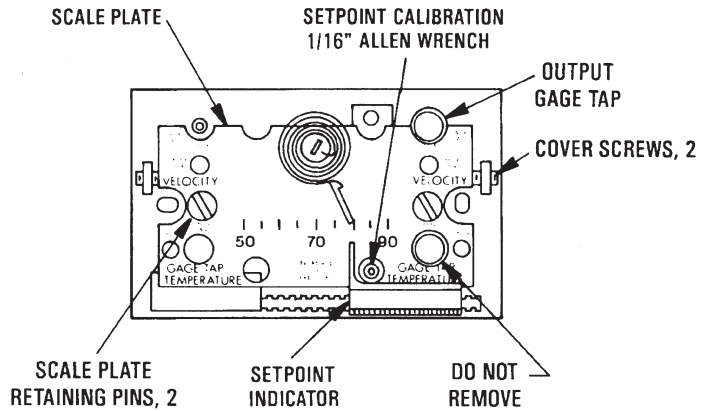

Cover Height (not shown) = 1-7/8" (47 mm)

CAUTION

Pneumatic devices must be supplied with clean, dry control air. Any other medium (e.g., oil or moisture contamination) will cause the device to fail.

KMC Controls, Inc.

19476 Industrial Drive, New Paris, IN 46553

574.831.5250

www.kmcccontrols.com

info@kmcccontrols.com