

Description and Application

The electronic KMC VEF-56 series control butterfly valves are three-way, mixing or diverting valves for control of flow in high-capacity hot or chilled water applications. Valves range in size from 2" to 5" with modified equal percentage flow characteristics. The lug-style valves feature a stainless-steel disk and shaft with an EPDM seat to assure long life and bubble-tight shut off.

These valve assemblies are shipped as a complete assembled unit ready for field installation. Two valves are mounted on a ductile iron "T" having ANSI B16.1 Class 125 flanges. The Master valve is complete with an actuator while the second (Slave) valve is controlled through a connecting linkage. The valves are linked so that as one valve opens the other valve closes.

These valves use KMC MEP-7xxx series ControlSet actuators. An optional "fail-safe" feature allows failure to either inlet upon loss of 24 VAC supply — the capacitor-driven fail-safe models provide efficient operation with switch-selectable fail direction. The MEP-7xx2 proportional (0–10 VDC or 4–20 mA) models feature a switch-selectable, 0–5 or 0–10 VDC voltage feedback output that is proportional to the actuator position. A gear disengagement feature allows positioning of the valve stem/disk without energizing the actuator.

Accessories

CME-7001	Rotary aux. cam switch, single
CME-7002	Rotary aux. cam switch, double
HMO-4536	Adjustable stop kit
MEP-7xxx	Replacement actuator (see label on actuator or data sheet)



Features

- ◆ EPDM seat for bubble-tight shut-off
- ◆ Stainless-steel stems and disks
- ◆ Seat face negates need for flange gaskets
- ◆ Modified equal percentage flow characteristics
- ◆ Choice of tri-state (floating) or proportional (0–10 VDC or 4–20 mA) inputs on MEP-7xxx series ControlSet actuators
- ◆ Non-fail-safe or fail-safe (with switch-selectable direction and efficient, durable, capacitor-driven-operation) models
- ◆ Gear disengagement for manual valve operation
- ◆ Removable terminals and 1/2" NPS conduit fittings
- ◆ Actuator position feedback option (MEP-7xx2 models)
- ◆ Optional adjustable end stop (HMO-4536) and adjustable auxiliary switches (CME-7001/7002)

Models

Model #	Size*	Actuator	Weight (lbs.)
VEF-5608ARF	K ** 2"	MEP-7202, proportional	28.2
	F ** 2"	MEP-7201, tri-state	28.2
	L ** 2"	MEP-7252, proportional, fail-safe	28.6
	H ** 2"	MEP-7251, tri-state, fail-safe	28.6
VEF-5610ARG	K ** 2.5"	MEP-7502, proportional	28.2
	F ** 2.5"	MEP-7501, tri-state	28.2
	L ** 2.5"	MEP-7552, proportional, fail-safe	28.6
	H ** 2.5"	MEP-7551, tri-state, fail-safe	28.6
VEF-5612ARH	K ** 3"	MEP-7802, proportional	32.6
	F ** 3"	MEP-7801, tri-state	32.6
	L ** 3"	MEP-7852, proportional, fail-safe	33.0
	H ** 3"	MEP-7851, tri-state, fail-safe	33.0
VEF-5616ARH	K ** 4"	MEP-7802, proportional	45.9
	F ** 4"	MEP-7801, tri-state	45.9
	L ** 4"	MEP-7852, proportional, fail-safe	46.3
	H ** 4"	MEP-7851, tri-state, fail-safe	46.3
VEF-5620ARJ	K ** 5"	(2) MEP-7802, 0-10 VDC***	65.3
	F ** 5"	(2) MEP-7801, tri-state	65.3
	L ** 5"	(2) MEP-7852, 0-10 VDC, fail-safe***	66.1
	H ** 5"	(2) MEP-7851, tri-state, fail-safe	66.1

***NOTE: 4-20 mA inputs are not available in Master-Slave applications (5" valves).

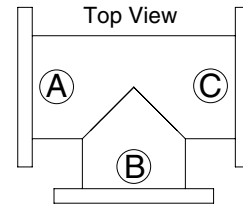

**ARRANGEMENT	Master Valve (Actuator)	Slave Valve	Common Port
1	A	B	C
2	A	C	B
3	B	C	A
4	B	A	C
5	C	B	A
6	C	A	B

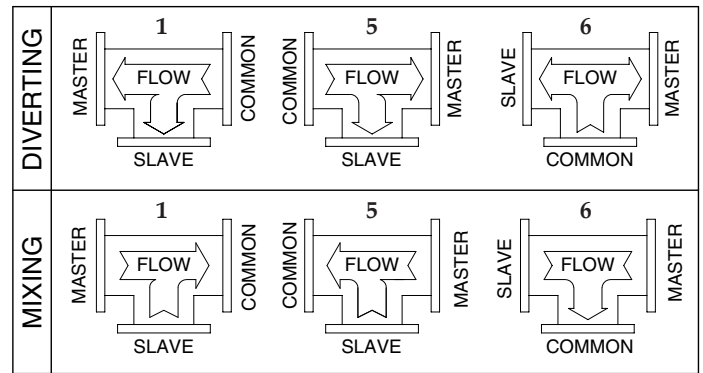

(Arrangements 2 and 4 not illustrated – see Ordering Example for Arrangement 3)

****Desired Arrangement 1-6 must be included as a suffix on the valve assembly model number. See the charts above and consider these guidelines:**

- Each port is designated by A, B, or C.
- Arrangement numbers are based on the top view looking down on the "T" and top of the valve shaft as shown in the chart.
- Select which port is the master and which port is to be the slave and use the table to choose the corresponding arrangement number.
- Add selected arrangement number to the end of the valve assembly model number (see Ordering Example).

*Cv Values by Size and Disk Position (US GPM @ 1 ΔP)									
Size	Position of Disk								
	10°	20°	30°	40°	50°	60°	70°	80°	90°
2	0.06	3	7	14	26	42	67	101	111
2.5	0.10	6	12	24	43	72	114	171	188
3	0.19	9	17	38	67	112	176	263	290
4	0.29	16	35	75	134	195	350	525	577
5	0.48	28	59	128	228	377	596	894	983

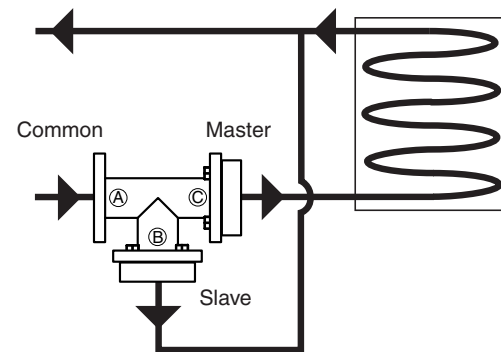

Arrangement 5 DIVERTING Flow Example

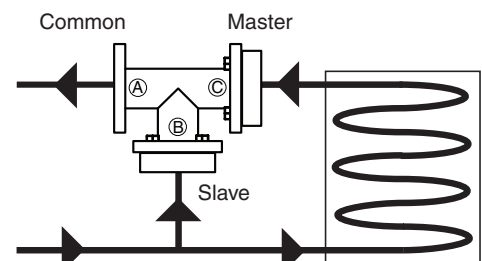

Arrangement 5 MIXING Flow Example

Actuator (all configurations) full CCW:

- Master valve **closed**
- Slave valve **open**

Actuator (all configurations) full CW:

- Master valve **open**
- Slave valve **closed**

NOTE: The actuator on the Master valve is oriented parallel with the pipe as shown in the Ordering Example.

NOTE: If a fail-safe actuator is used, the fail direction can be selected with the CW/OFF/CCW switch.

NOTE: For sizes larger than 5 inches, contact Valve Solutions, Inc. (www.valvesolutions.com).

Ordering Example

2-1/2" 3-way valve with MEP-7502 actuator:

- Master valve on Port "B"
- Slave valve on Port "C"
- Common Port "A"

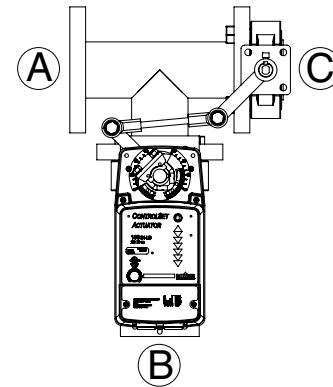

Dimensions

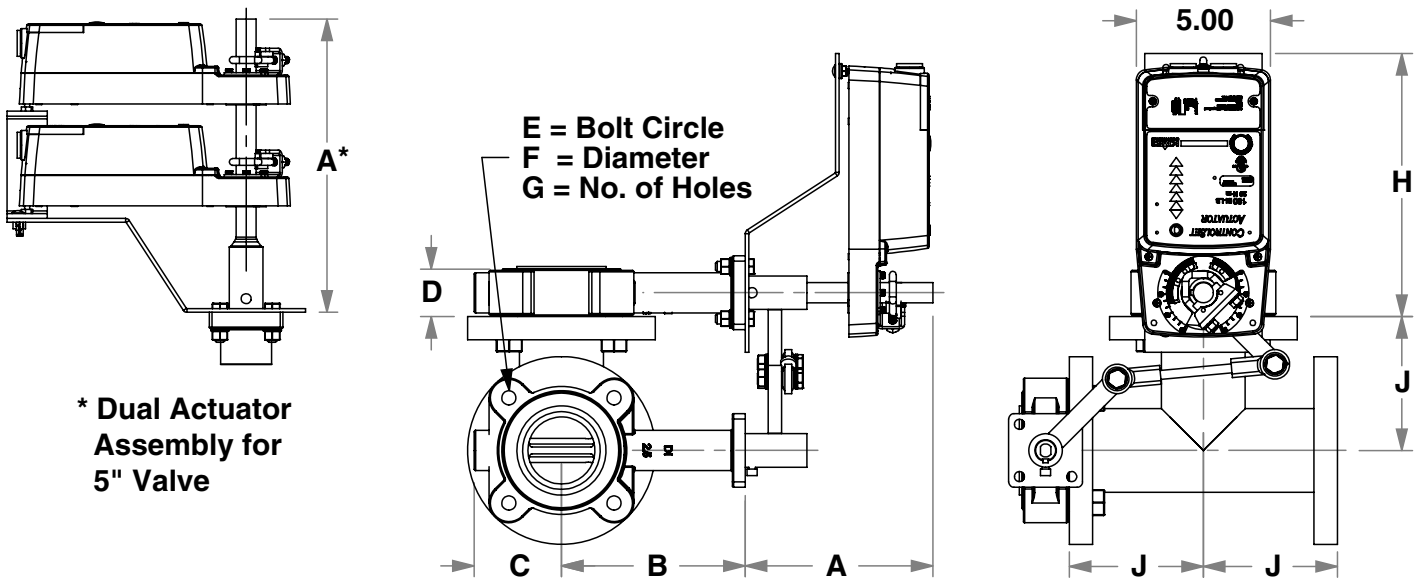

* Dual Actuator Assembly for 5" Valve

Dimensions in inches

NOTE: "D" is the face to face dimension of the valve body. This does not account for the valve seat. Approximately 1/8" additional spacing is required for proper seating with the pipe flanges. The installation does not require gaskets since the valve seat creates the seal against the mounting flange. These valves are designed to be installed between ANSI B16.1 Class 125 (Iron) and Class 150 (Steel) pipe flanges.

Size	A	B	C	D	E	F	G	H	J
2"	7	6.34	3.35	1.69	4.75	5/8-11	4	9.77	4.5
2.5"	7	6.89	3.66	1.81	5.5	5/8-11	4	9.83	5
3"	7	7.13	3.9	1.81	6	5/8-11	4	9.83	5.5
4"	7	7.87	4.57	2.05	7.5	5/8-11	8	9.95	6.5
5"	11*	8.39	5.12	2.2	8.5	3/4-10	8	10	7.5

Specifications

Actuator

Supply Voltage 24 VAC (+20%/–15%) Class 2, or 22–35 VDC

Supply Power

MEP-720x/750x 6 VA

MEP-725x/755x 8 VA normal (25 VA peak while initializing)

MEP-780x 8 VA

MEP-785x 10 VA normal (40 VA peak while initializing)

Control Input

Tri-state (See Supply Voltage)

Proportional 0–10 VDC or (except on Master-Slaves) 4–20 mA

Feedback

Proportional 0–5 VDC or 0–10 VDC (switch selectable)

Motor Timing

(Powered)
MEP-72xx 75–90 seconds, load dependent

MEP-75xx/78xx 90–115 sec., load dependent

Fail-Safe Timing

(Switch-selectable clockwise, counter-clockwise, or off; up to 40 second delay while charging capacitor after initial connection to power)

MEP-725x 65–100 sec., load dependent

MEP-755x/785x 80–115 sec., load dependent

Connections

Wire clamp type; 14–22 AWG, copper

Enclosure

Flame retardant plastic

Noise Level

< 45 dbA max. at 1 meter

Approvals

UL 873 Temperature Indicating and Regulating Equipment

FCC Class B, Part 15, Subpart B

Environmental Limits

Operating –22 to 131° F (–30 to 55° C)

Shipping –40 to 176° F (–40 to 80° C)

Humidity 5 to 95% RH (non-condensing)

NOTE: For more information, see the MEP-7200/7500/7800 series data sheet.

Valve Body

Max. Differential Pressure 100 psi

Action Three-way mixing or diverting

Body Type ANSI 125/150 flanges, lug body style

Valve Sizes 2" through 5" flange

Flow Characteristics Modified equal percentage

Sizes & Cv Ratings See the chart in the Models section

Actuators See the Models and Actuator sections as well as the MEP-7200/7500/7800 series data sheet

Material

Body Ductile iron

Disc 304 stainless steel

Seat EPDM

Shaft 416 stainless steel

Bushing PTFE

Environmental Limits

Medium –30 to 275° F (–34 to 135° C)

Ambient –22 to 131° F (–30 to 55° C)

Shipping –40 to 176° F (–40 to 80° C)

▲ CAUTION

Freeze protection required for fluid temperatures below 32° F (0° C).

▲ CAUTION

Using mineral oil lubricants or other incompatible substances in system fluids may damage EPDM rubber seats in valves. Before using any lubricant or additive in a water or ethylene glycol base, consult the substance manufacturer for compatibility with EPDM (Ethylene Propylene Diene Monomer).

KMC Controls, Inc.

19476 Industrial Drive, New Paris, IN 46553

574.831.5250

www.kmcccontrols.com

info@kmcccontrols.com